

PERI Rental Criteria

Slab Table Trolley

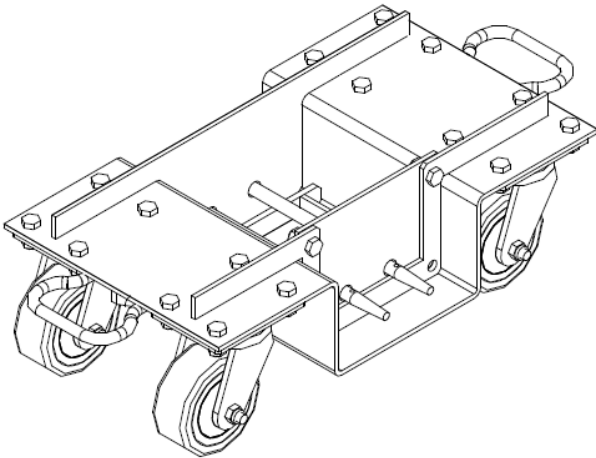

Contact

PERI GmbH
Formwork Scaffolding
Engineering

P.O. Box 1264
 89264 Weißenhorn; Germany
 Phone +49 (0) 7309.950-0
 Fax +49 (0) 7309.951-0
 rental-criteria@peri.de

Content	Page
Slab Table Trolley	2
Glossary	7

Changes made	Date Initial	Page
New Version	06/03/2025 aal	

PERI Rental Criteria

Slab Table Trolley



Slab Table Trolley	No.	Name	Article number
--------------------	-----	------	----------------

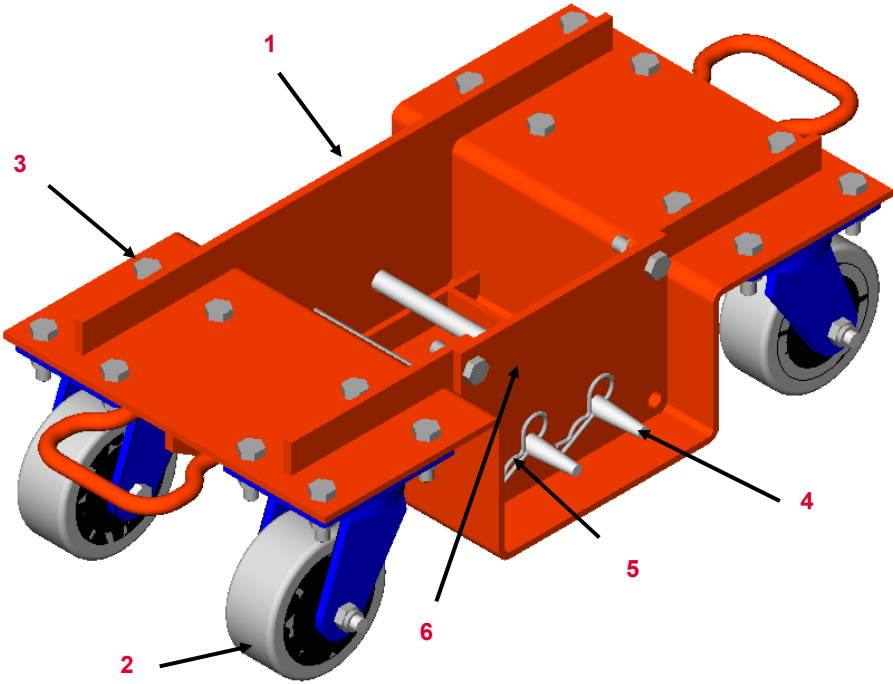

- 1 Slab Table Body
- 2 Heavy Duty Wheel
- 3 Bolt, Nut & Washer M12 x 40 mm, G8.8
- 4 Pin Ø 16 x 295, galv.
- 5 Cotter Pin Ø 4 mm
- 6 Plate

PERI Rental Criteria

Slab Table Trolley



Steel Waler SRU SRZ	Description	Instruction	Billing Condition	Type
---------------------	-------------	-------------	-------------------	------



Missing Plate, Pin and cotter pin



Foreign material embedded into wheel

- If possible



- Or if not possible



PERI Rental Criteria

Slab Table Trolley



Steel Waler SRU SRZ	Description	Instruction	Billing Condition	Type
---------------------	-------------	-------------	-------------------	------



Damaged greasing nipple











Damaged wheel (Cannot Rotate)



PERI Rental Criteria

Slab Table Trolley







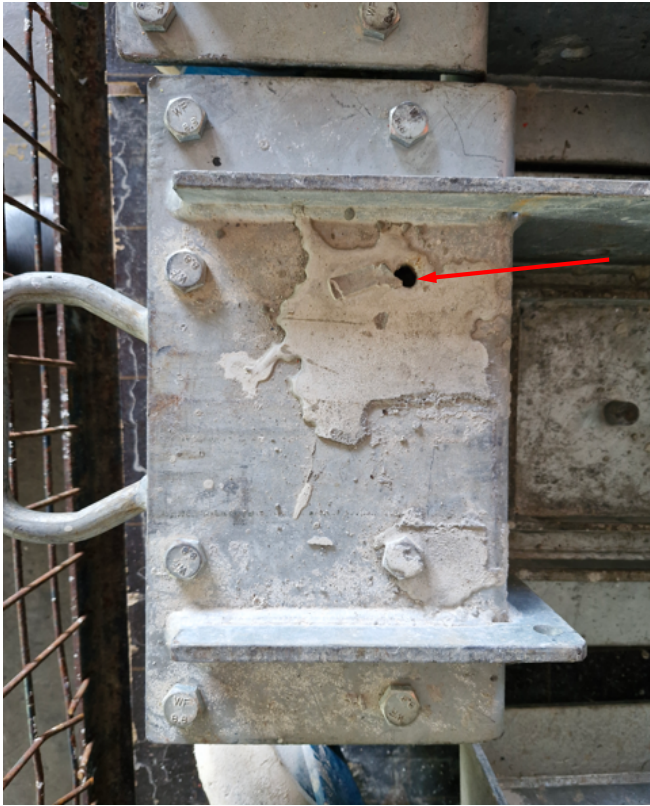

Steel Waler SRU SRZ	Description	Instruction	Billing Condition	Type
	<p>Damaged Wheel (Chipped Off)</p>			
	<p>Damaged Wheel (Profile damaged)</p>			

PERI Rental Criteria

Slab Table Trolley



















Steel Waler SRU SRZ	Description	Instruction	Billing Condition	Type
	<p>Missing Bolt/Nut</p>			
	<p>Soiling</p>			

PERI Rental Criteria

Glossary Icons



Icon	Significance	Icon	Significance	Icon	Significance
	Not OK – material is scrap		Billing necessary (customer)		Optical damage
	OK—material stays in rental park		No Billing necessary		Functional damage
	Scrap material—it's not permitted to hand out the material because of safety aspects		Shorten material		Functional damage—it's not permitted to hand out the material
	Repair according to Instruction		Mark material		Static damage—it's not permitted to hand out the material
	Fix material cold– Afterwards check weld seams and bordering components		Replace damaged material		
	Repair after local economic efficiency calculation		Replace missing material		
	Clean material				